

# Rail Kit RKS-01 & RKS-04

## Quick Installation Guide

### Prepare For Installation

- Register your Synology product at [account.synology.com](http://account.synology.com)
- For technical support, visit [www.synology.com/support](http://www.synology.com/support)

### Warranty Notice

The warranty period starts from the purchase date stated on your receipt or invoice, so we recommend you keep your purchase receipt or invoice in a safe place. For more information, please visit [www.synology.com/company/legal/warranty](http://www.synology.com/company/legal/warranty)

### Please read this section carefully before installing the rail kit.

- Choosing a setup location:
  - The server chassis should be in a clean, dust-free, and well-ventilated environment. Avoid areas where heat, electrical noise, or electromagnetic fields are generated.
  - Leave enough clearance (about 25 inches) in front of the rack so you can open the front door completely.
  - Leave enough of clearance (about 30 inches) on the back of the rack to allow sufficient space for airflow and access when servicing.
  - This product should only be installed in restricted access locations, such as dedicated equipment rooms or service closets.
- Rack precautions:
  - Make sure to read the installation instructions before sliding the rack out.
  - Make sure that the leveling jacks on the bottom of the rack are extended to the floor so the full weight of the rack rests on them.
  - Do not put any objects on top of slide rail mounted equipment.
  - Do not leave slide rail mounted equipment unattended while it is extended.

### Warning!

Stability hazard:

- Before sliding the unit out for servicing, the rack-stabilizing mechanism must be in-place or the rack must be bolted to the floor.
- The rack may tip over, causing equipment/property damage or serious personal injury.

### Package Content

- Screw x 4 (M5\*7L mm, PH2)
- Inner rail screw x 4 (M4\*4L mm, PH2)
- Round hole pin x 4

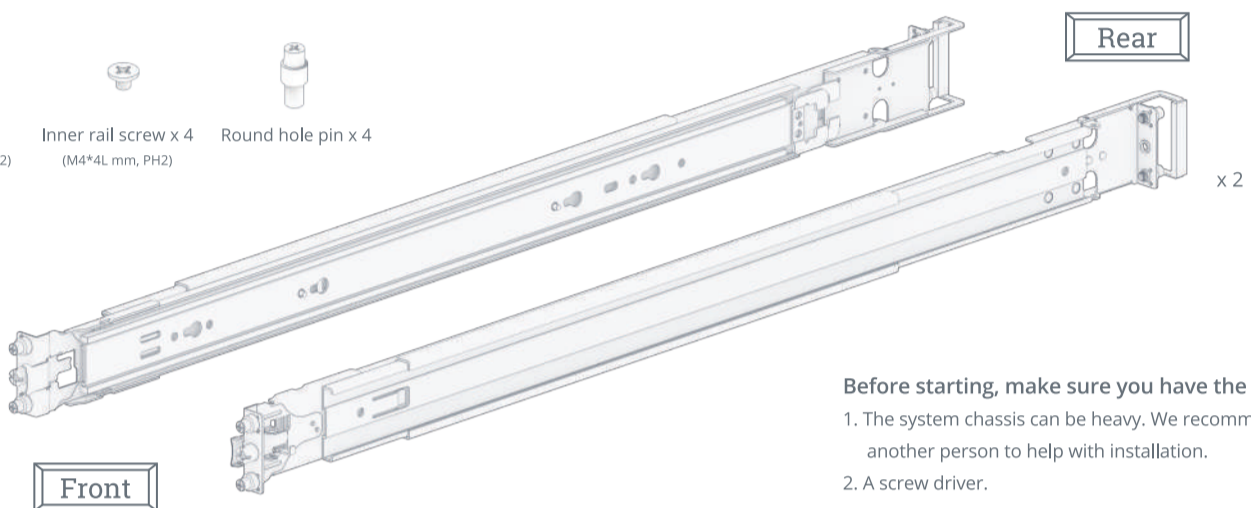

- Before starting, make sure you have the following:**
- The system chassis can be heavy. We recommend asking another person to help with installation.
  - A screw driver.

## Installation

### 01

- Check hole type on rack post. Choose suitable pin or bracket to install if needed.
  - A 9.5 Square Hole (Pre-installed)
  - B 7.1 Round Hole
- Attach the rear end of the rail kit assembly to the rack by pushing the latch and inserting the bracket into the rack holes.

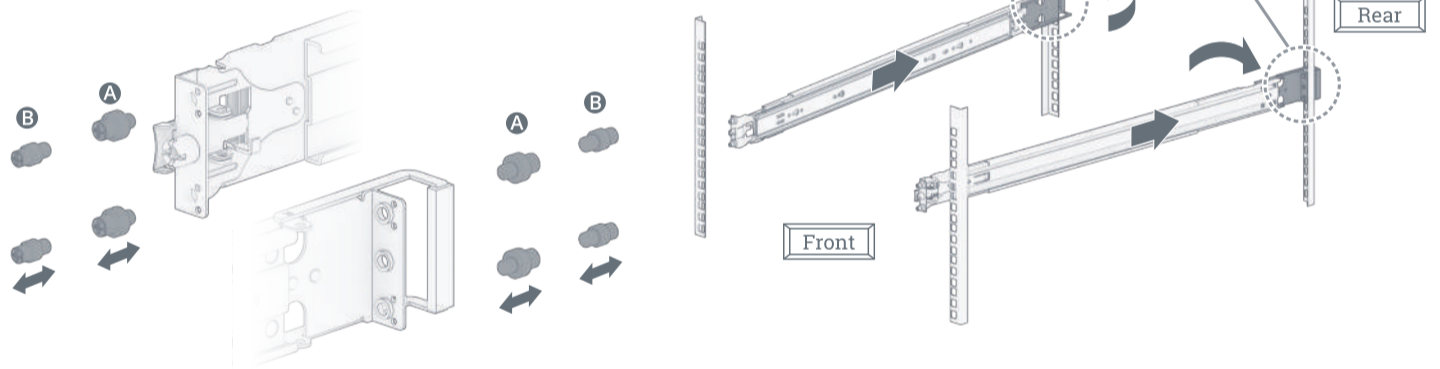

### 02

- Adjust the length of the rail kit assembly, and insert the front end to the rack by slightly sliding the front latch outwards and inserting the brackets into the rack holes.

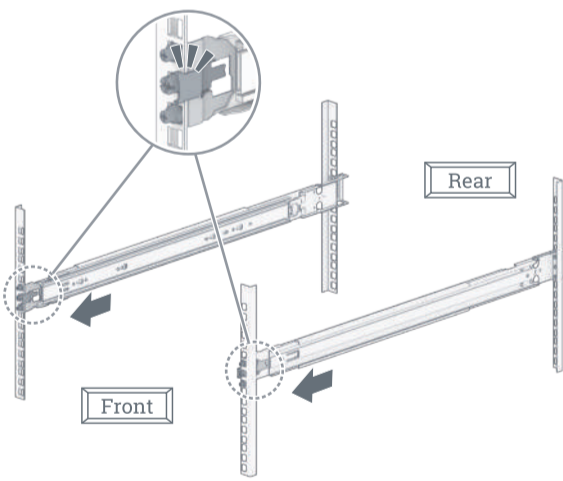

### 03

- Fully extend the inner rail outwards until you hear a click sound.
- Pull and hold the rear latch on the inner rail, as illustrated, and continue to pull out the inner rail from the assembly.

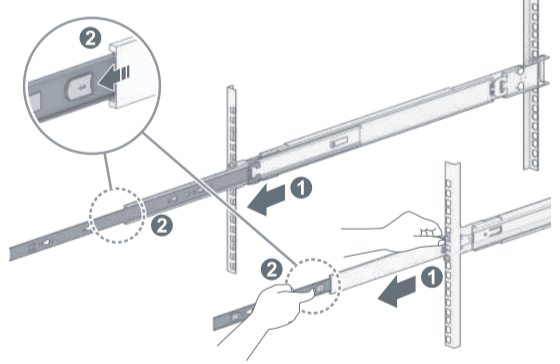

### 04

- Align the fixing holes of the inner rail to the side of the chassis and slide backward to attach the inner rail.
- Secure the rail screws as illustrated.

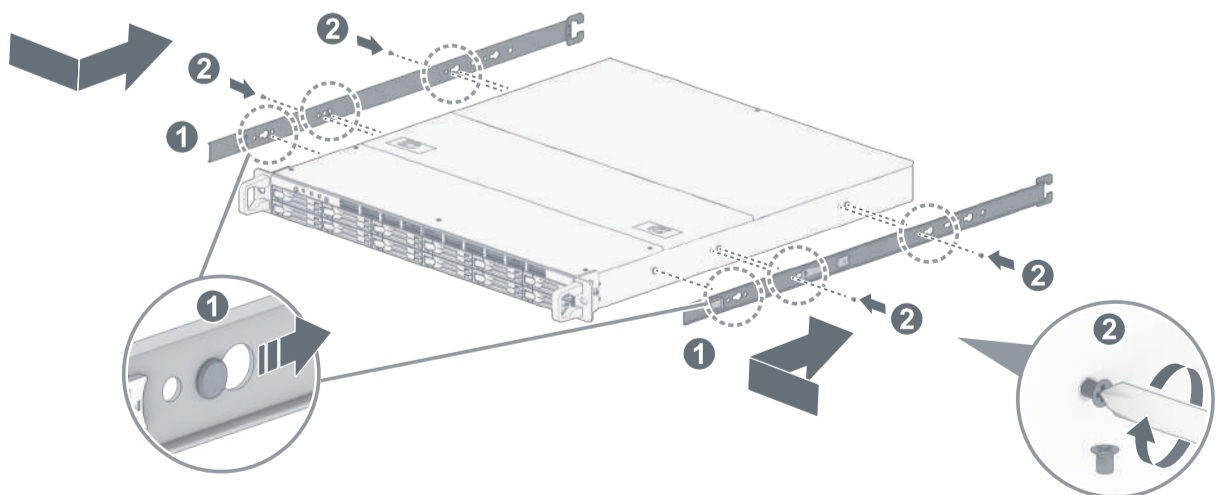

### 05

- With the help of another person, carefully align the inner rails to the outer rail assembly, and push the chassis towards the rack.

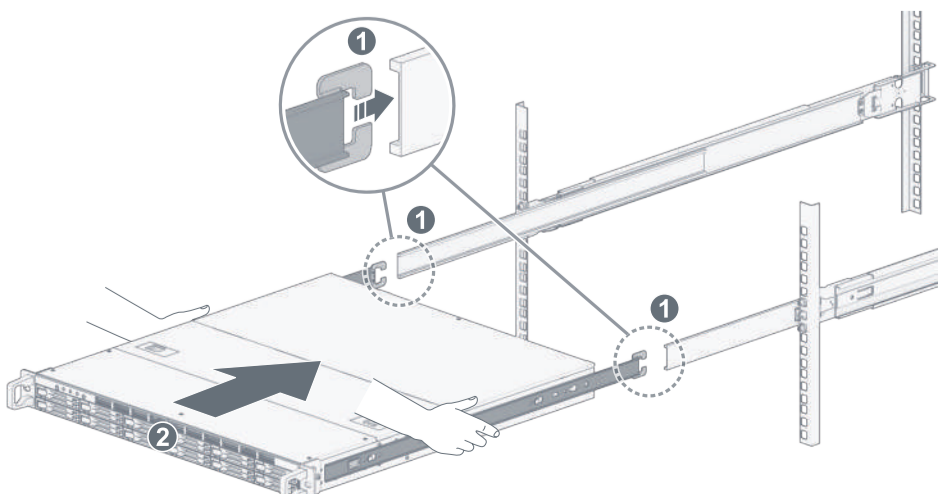

**06** Pull the front latch of the inner rail as illustrated to unlock the inner rail, and continue pushing the chassis towards the rack.

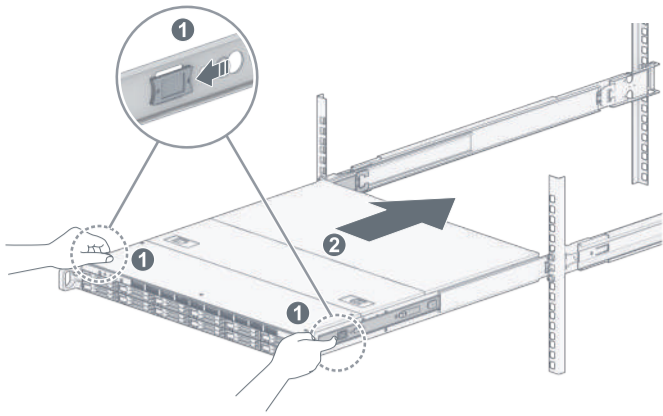

**07** Push the chassis into the end of rack and secure the ear holder to the rack.

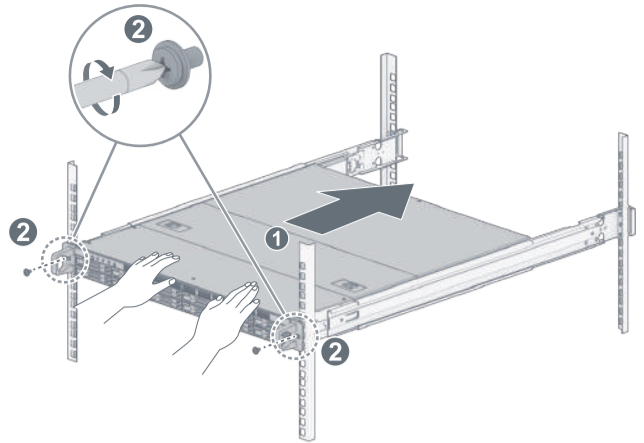

## Removal

### 01

To remove the chassis from the rack, loosen and remove the screws from the rack.

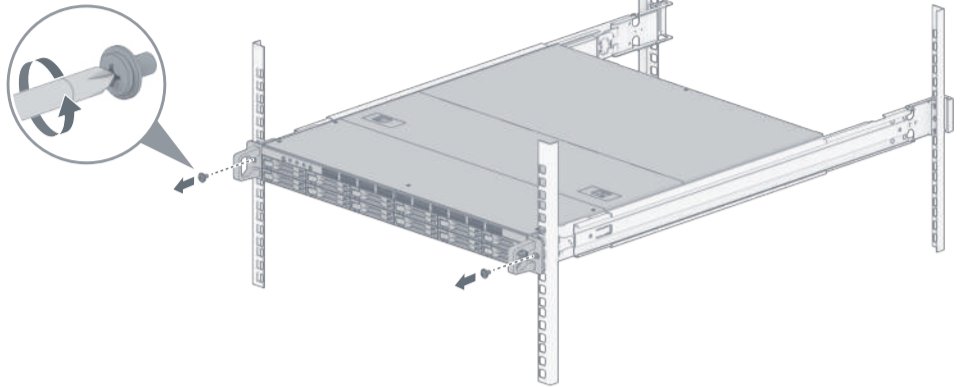

**02** Pull out the chassis from the rack.

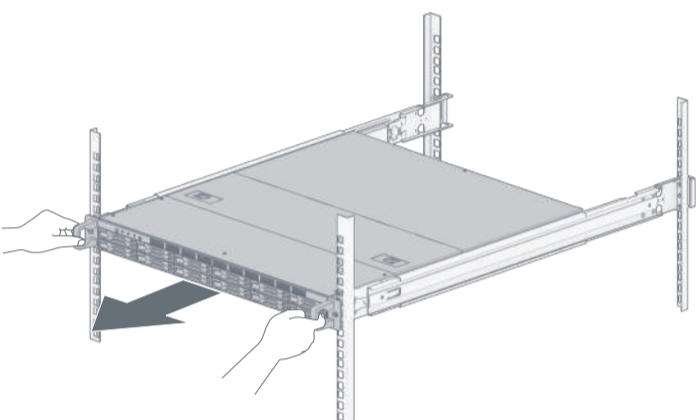

**03** Slide outwards the rear latch of the inner rail to unlock the inner rail from the outer rail assembly. With the help of another person, carefully remove the chassis from the rack. (You may remove all drives first to reduce the weight of the chassis.)

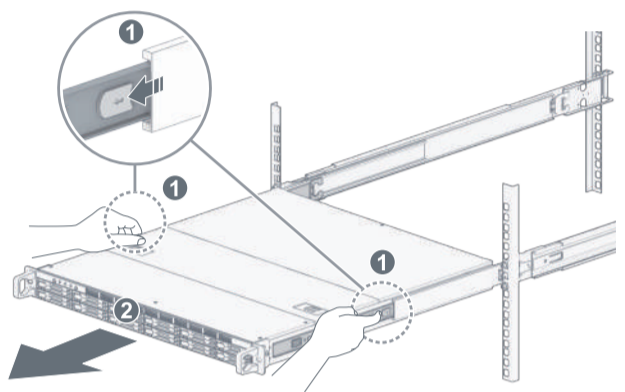

**04** Loosen and remove the rail screws. Slightly pull out the middle latch as illustrated, and slide forwards to remove the inner rail from the chassis.

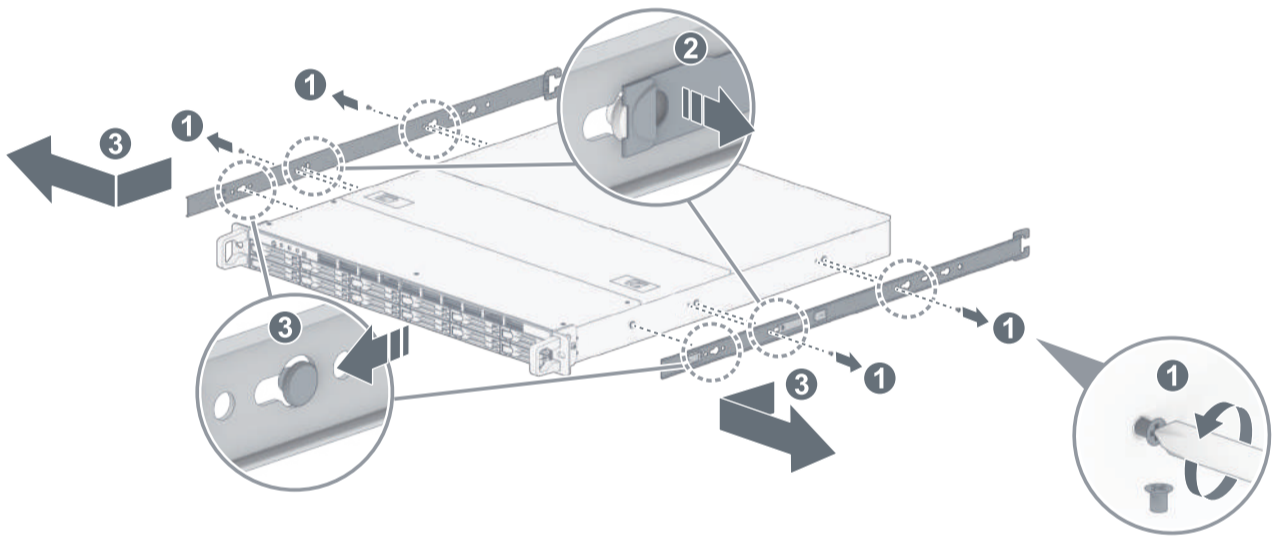

**05** Insert the inner rail to the rail kit assembly by pulling outwards and holding its front latch.

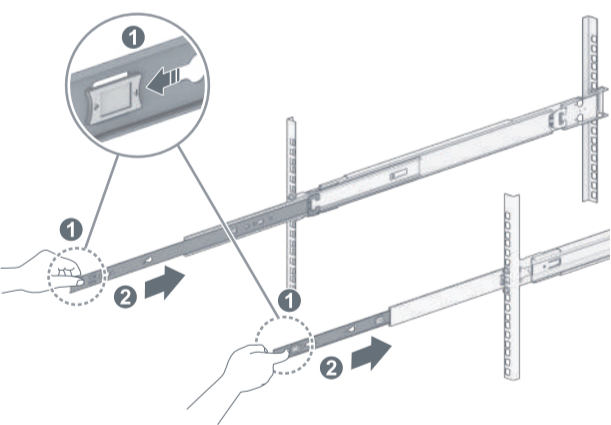

**06** Push the front latch of the inner rail assembly, and slide backwards to remove the assembly from the rack.

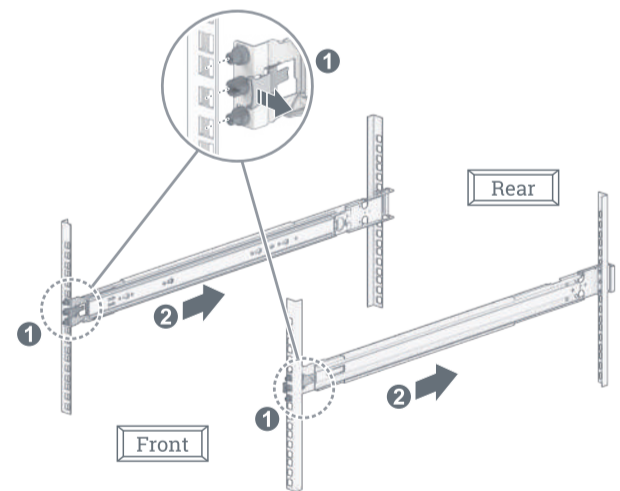

**07** Pull the rear latch of the inner rail assembly, and slide forwards to remove the assembly from the rack.

